

----- Isabelle -----

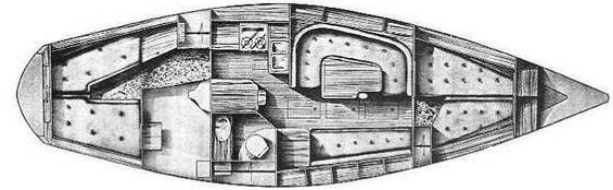
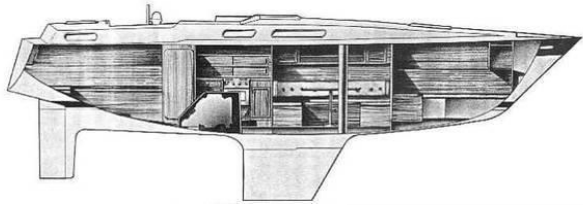

**Scanmar 35 # 68**

Built in Ornskoldsvik, Sweden 1985

100 where built and approximately 20 where exported to the US.

All sold at the Polarus Marina, Rock Hall MD

**Specifications**

1. General

a. LOA .....		10,70 m (35,1 ft)
b. LVL.....		8,40 m (27,5 ft)
c. Beam.....		3,30 m (10,8 ft)
d. Draft keel.....		1,77 m (5,8 ft)
e. Total Weight .....		5 400 kg (11 900lbs)
f. Keel Weight .....		1 890 kg (4 165 lbs)
g. Height (Vertical Clearance).....		15,40 m (50,5 ft)
h. LYS SVG (Spinnaker,Folding,G1).....		1,14
i. DH-88.....		6,45
j. TA2000.....		710

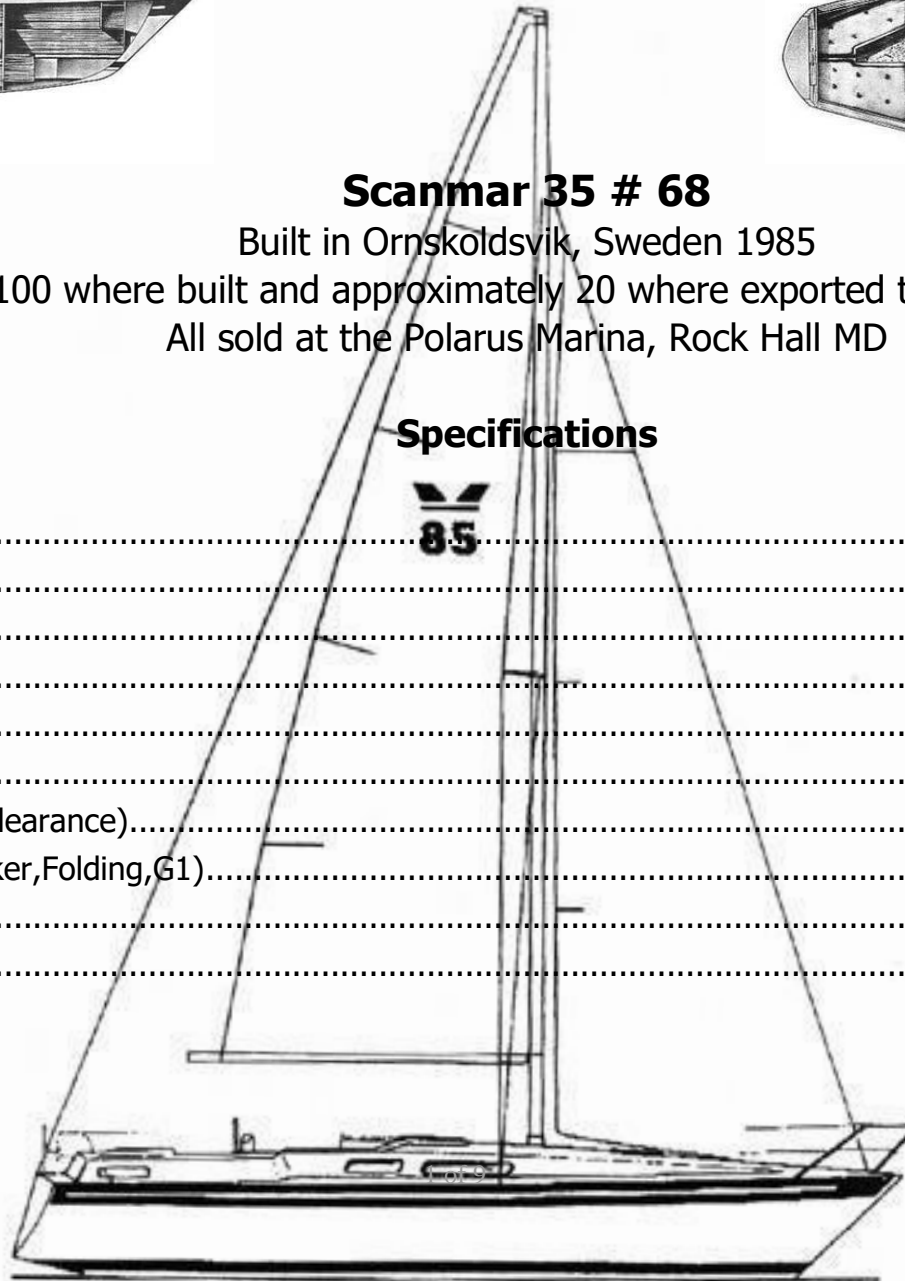

# ----- Isabelle -----

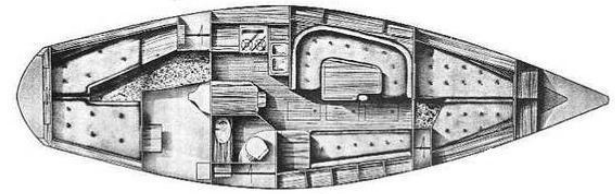
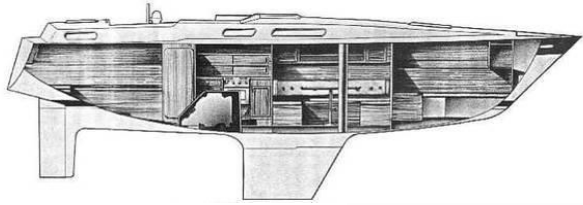

## 2. Sail measurements

a. P .....	12,55 m (41,17 ft)
b. E .....	3,70 m (12,14 ft)
c. T .....	12,10 m (39,69 ft)
d. LP .....	5,70 m (18,70 ft)
e. J .....	3,80 m (12,46 ft)
f. SL .....	11,95 m (39,20 ft)
g. SBR .....	6,84 m (22,44 ft)
h. SPL .....	3,80 m (12,46 ft)

## 3. Propulsion

a. Volvo Penta D1-30A/MS10A-B .....	28,4 Hp (20.9 kW) ISO8655
b. Weight .....	138 kg (304 lbs)
c. Cylinders .....	3
d. Norm/Max rpm .....	2800/3200 rpm
e. Engine Oil .....	3,5 lit (1,03 US gallons)
f. Gearbox Oil .....	0,35 lit (0,09 US gallons)
g. Cooling system .....	4,0 lit (1,05 US Gallons)
h. Displacement .....	1130 ccm <sup>3</sup> (68,1 inch <sup>3</sup> )
i. Gearbox Reduction Ratio .....	2,35:1

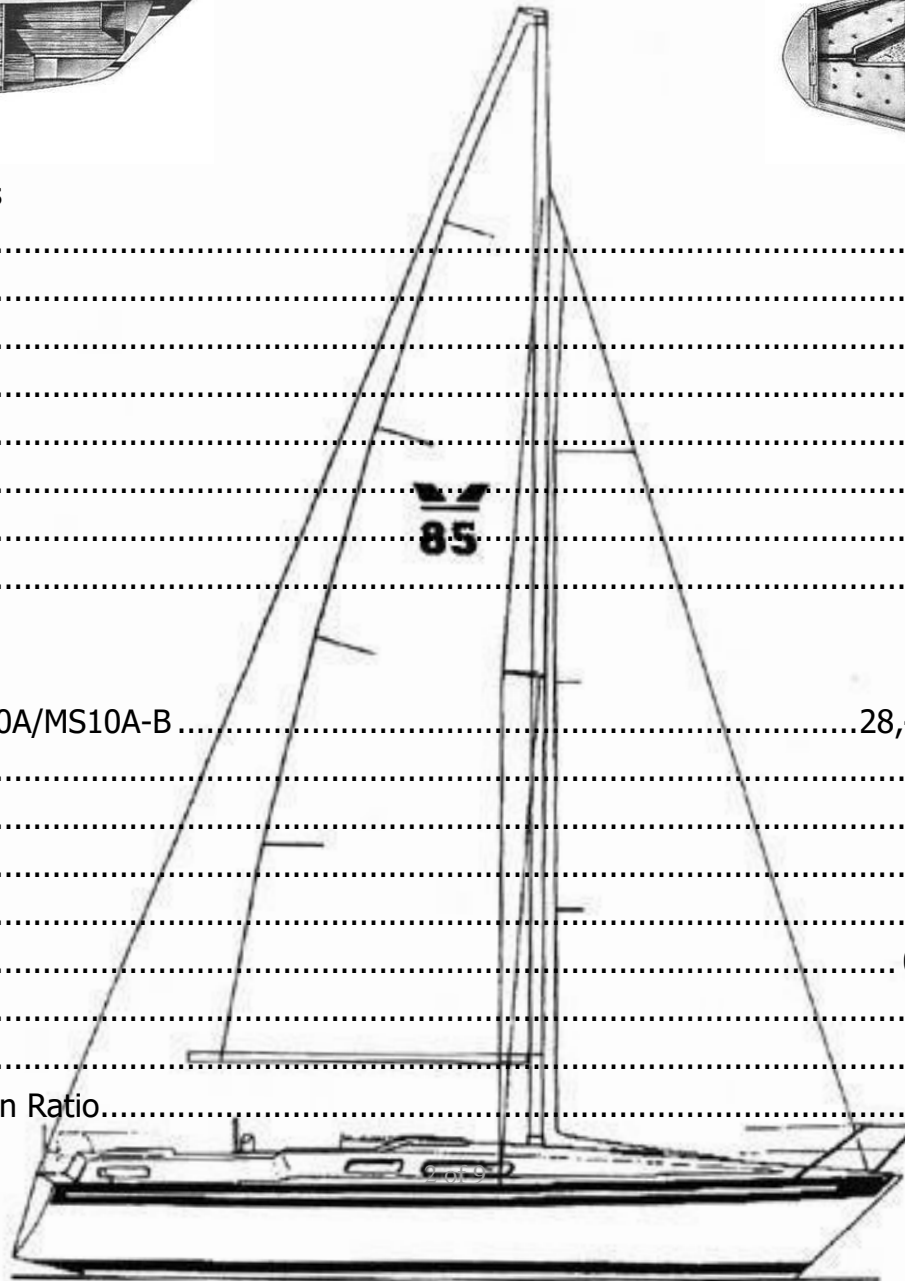

----- Isabelle -----

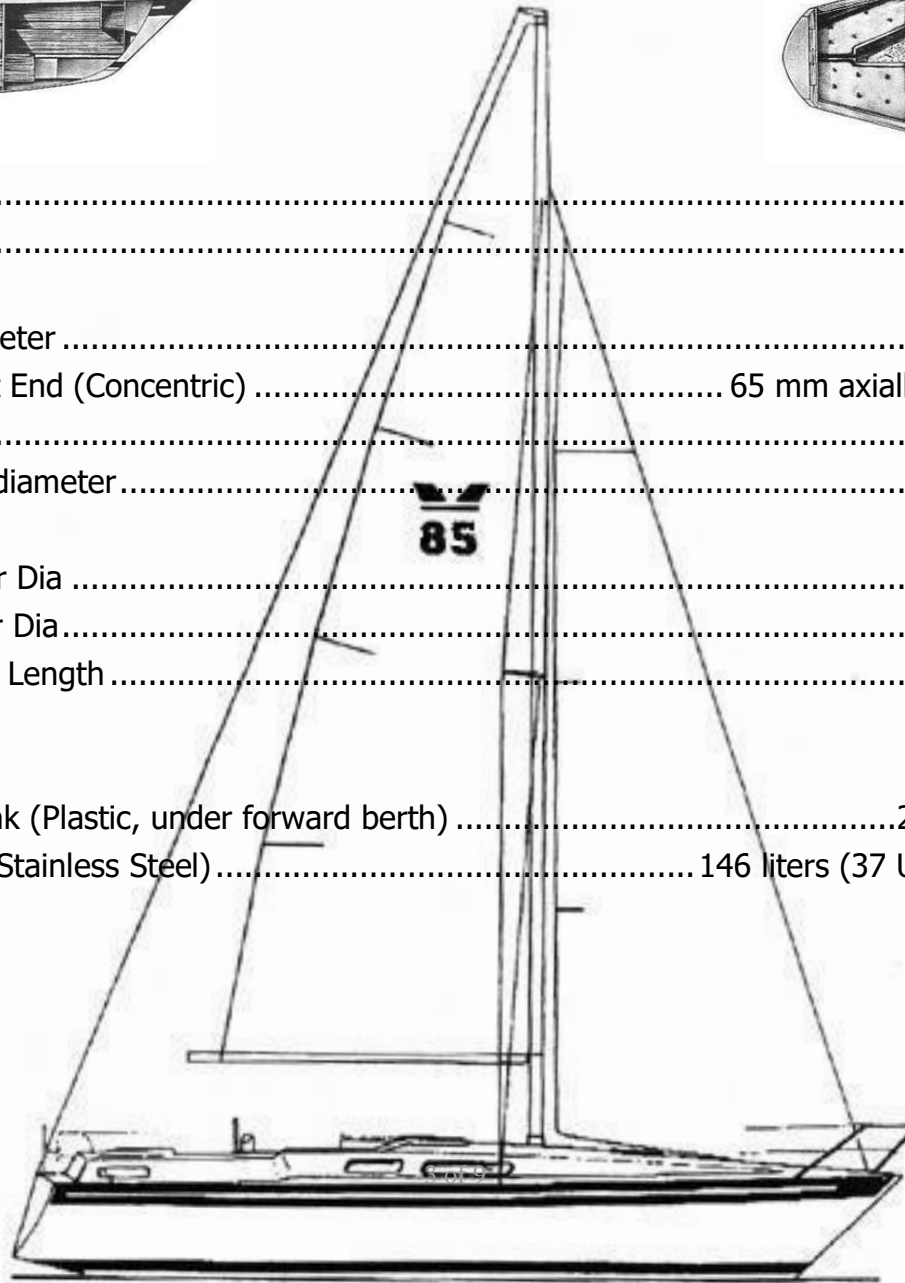
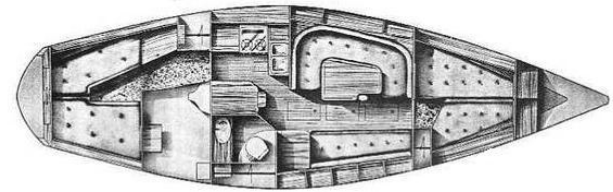
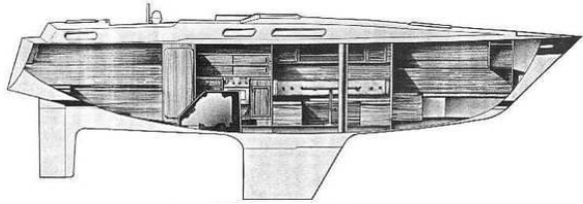

- j. Generator .....14V/115 Amp
- k. Starter Motor .....2,7 Hp (2,0kW)
- l. Propeller shaft
  - i. Diameter .....25,00 mm
  - ii. Shaft End (Concentric) ..... 65 mm axially and 25-22 mm radially
  - iii. Key .....55x10 and 6 mm thick
- m. Stern tube outer diameter ..... 43 mm
- n. Cutlass bearing
  - i. Outer Dia ..... 1,50 inch
  - ii. Inner Dia .....25,00 mm
  - iii. Total Length ..... 4 inch
- 4. Fluid Quantities
  - a. Potable Water tank (Plastic, under forward berth) .....233 liters (60 US gallons)
  - b. Diesel Fuel tank (Stainless Steel) ..... 146 liters (37 US gallons) 45x50x65 cm

----- Isabelle -----

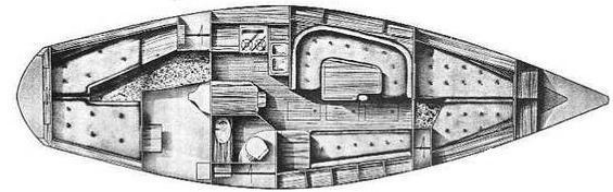
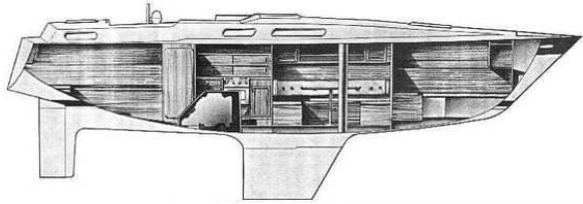

5. Standing Rig

- |                   |       |                 |
|-------------------|-------|-----------------|
| a. Forestay       | 7 mm  |                 |
| b. Top shroud     | 7 mm  | Turnbuckle 1/2" |
| c. Lower shroud   | 10 mm | Turnbuckle 5/8" |
| d. Aft stay       | 5 mm  |                 |
| e. Aft stay Sheaf | 3/16" |                 |

6. Running Rig

- |                  |           |            |
|------------------|-----------|------------|
| a. Genoa Halyard | Rope 3/8" | Wire 3/16" |
| b. Main Halyard  | Rope 3/8" | Wire 3/16" |

7. Mainsail Mast Track Plastic.

- |    |                                 |
|----|---------------------------------|
| a. | 34mm height                     |
| b. | 18mm width                      |
| c. | 3mm thick 21mm total thickness. |

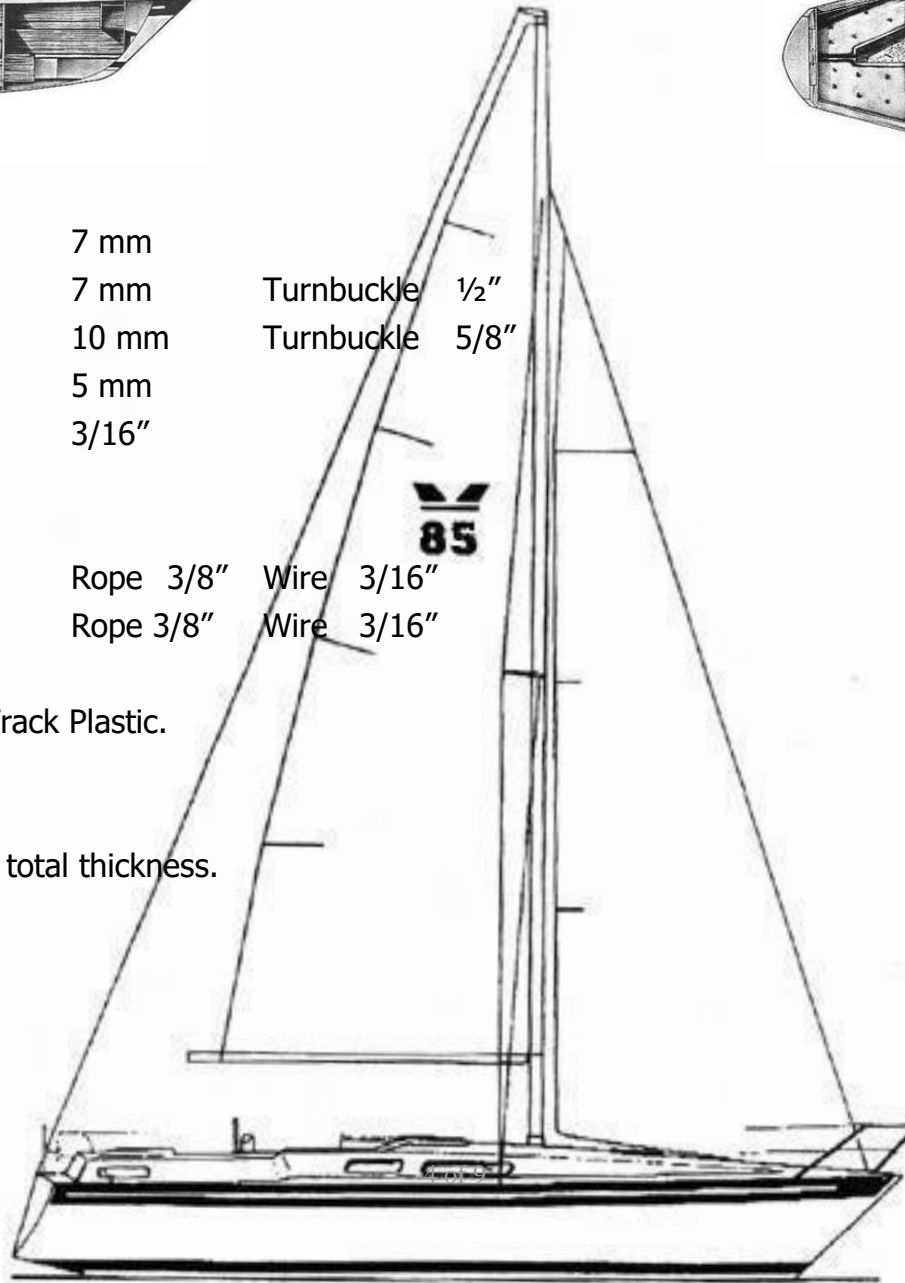

----- Isabelle -----

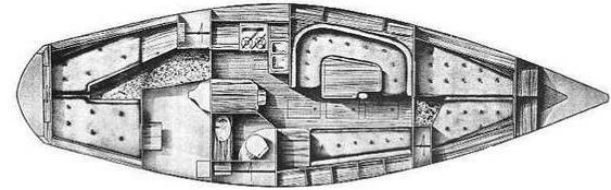
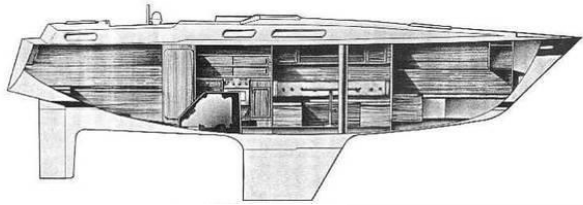

**Isabelle Equipment Inventory**

		Year
<b>1. Safety</b>		
a.	Radar reflector Firdell Blipper 210-7 .....	2004
b.	Bilge Pump Jabsco 50 lit/min .....	2004
c.	Bilge Pump Jabsco Submergible 125 lit/min .....	2004
d.	Chain plates.....	2004
<b>2. Navigation</b>		
	<b>85</b>	<b>Power Consumption</b>
a.	Raymarine RL70C Plus HSB <sup>2</sup> 7" (E52033) .....	9 W..... 2002
b.	Raymarine Plotter RC530 HSB 7" (E32035) .....	9 W..... 2003
c.	Raymarine Pathfinder Antenna 2kW 18" .....	9,0/28 W..... 2004
d.	Raymarine ST4000 MkII Plus (E12053) .....	0,72/10 W..... 2004
e.	Raymarine ST40 Rotovecta Wind (E22047).....	2005
f.	Raymarine ST40 Bidata (E22045) .....	2004
g.	Raymarine Raystar SDGPS 120 WAAS (E32025).....	1,5 W..... 2004
h.	Raymarine PC-SeaTalk-NMEA Interface Box (E85001) .....	2004
i.	Interphase Forwarding looking Scanner .....	2004
j.	Plastimo Compass 135 Baltic.....	2004
k.	JRJ Athena Electronic Heading Sensor 10Hz .....	2005

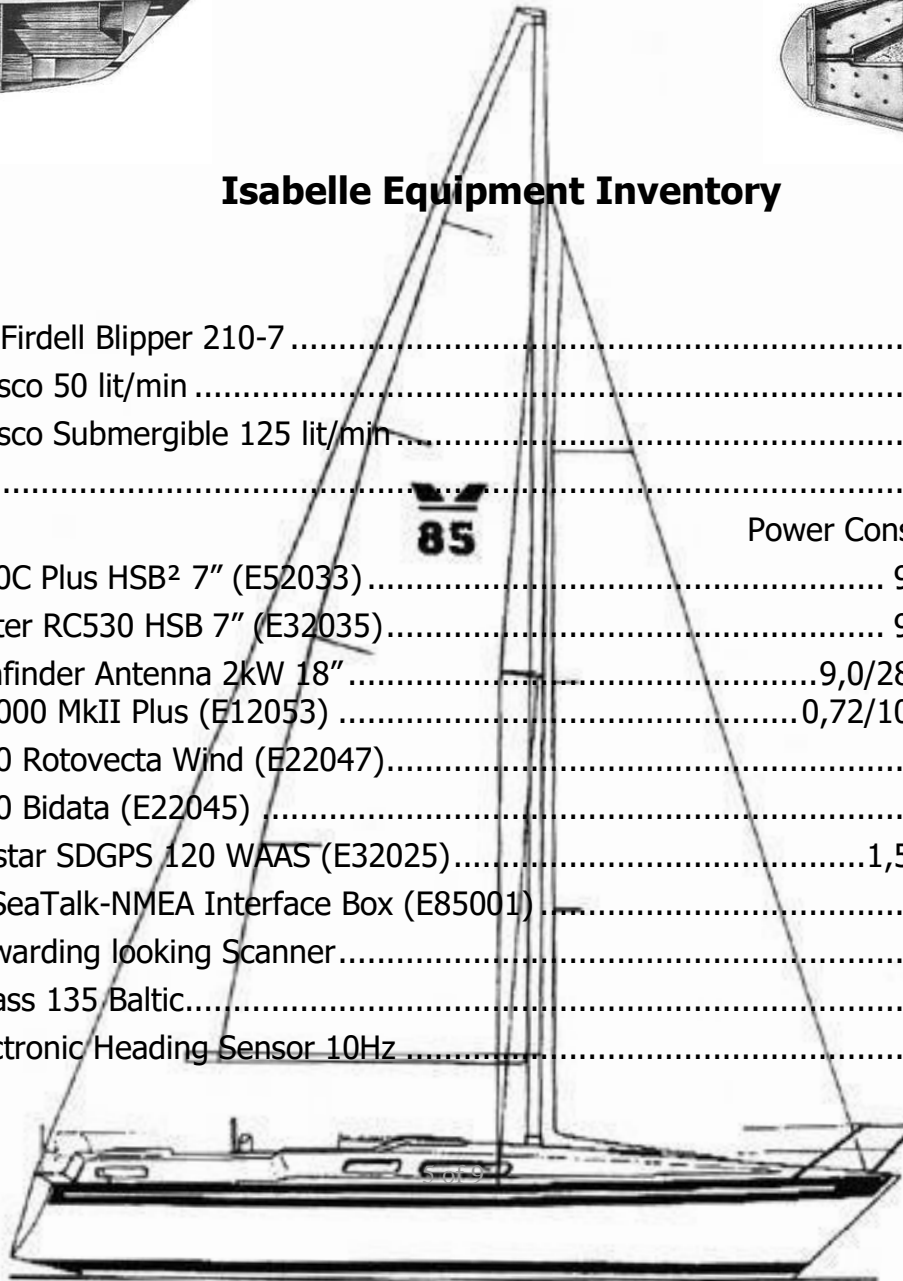

----- Isabelle -----

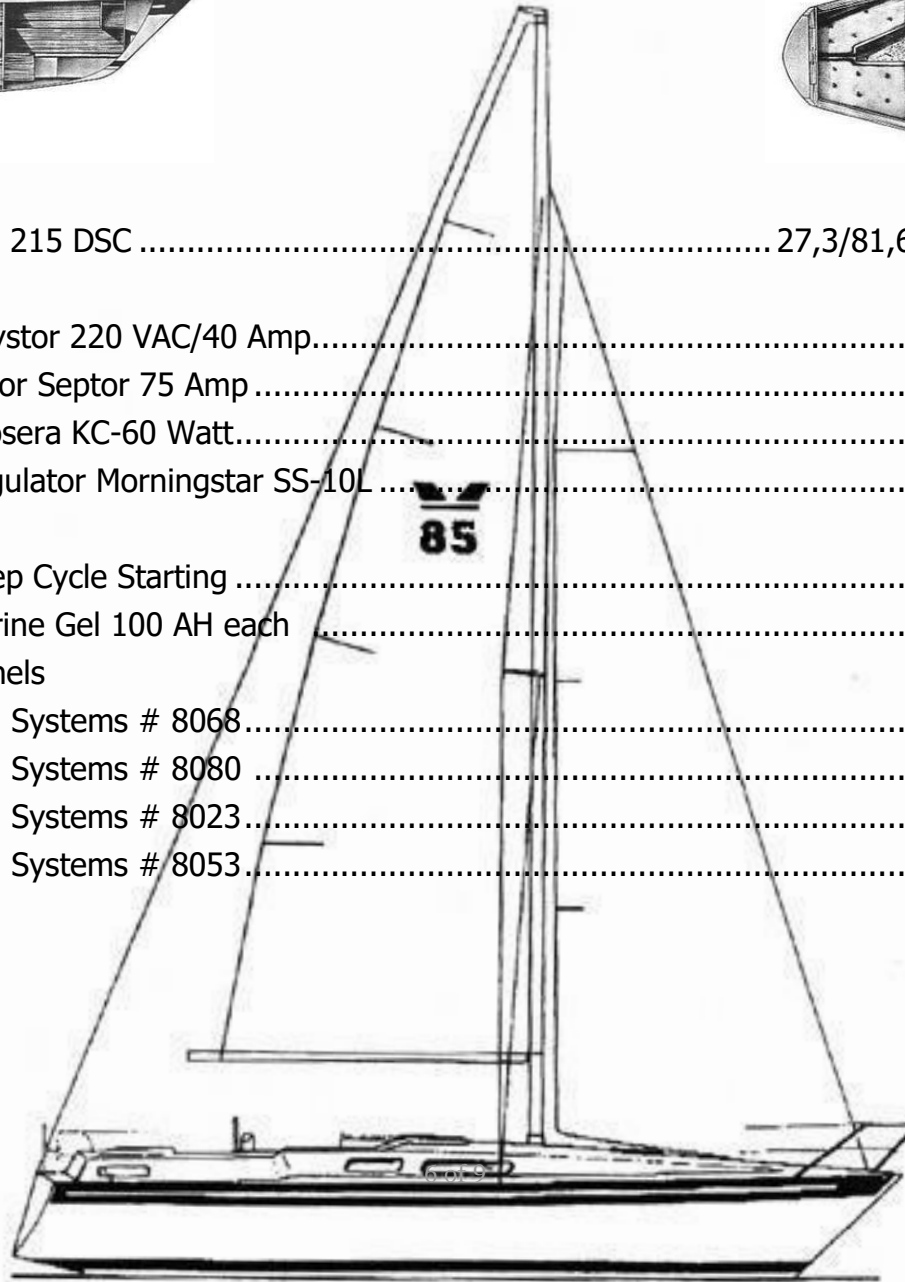
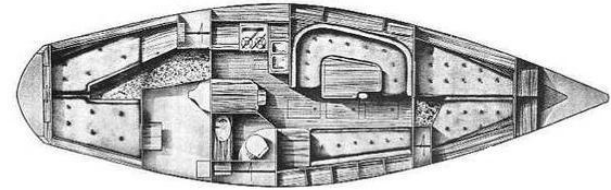
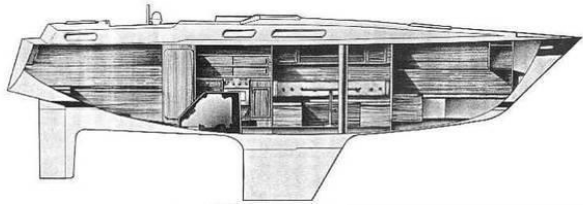

3. Communication

a. VHF Raymarine 215 DSC ..... 27,3/81,6 W ..... 2004

4. Electrical

a. Shore power Tystor 220 VAC/40 Amp ..... 2004

b. Battery separator Septor 75 Amp ..... 2004

c. Solar panel Kyosera KC-60 Watt ..... 2004

d. Solar panel Regulator Morningstar SS-10L ..... 2004

e. Batteries

i. 1 ea Deep Cycle Starting ..... 2004

ii. 2 ea Marine Gel 100 AH each ..... 2010

f. Distribution Panels

i. Blue Sea Systems # 8068 ..... 2004

ii. Blue Sea Systems # 8080 ..... 2004

iii. Blue Sea Systems # 8023 ..... 2004

iv. Blue Sea Systems # 8053 ..... 2004

# ----- Isabelle -----

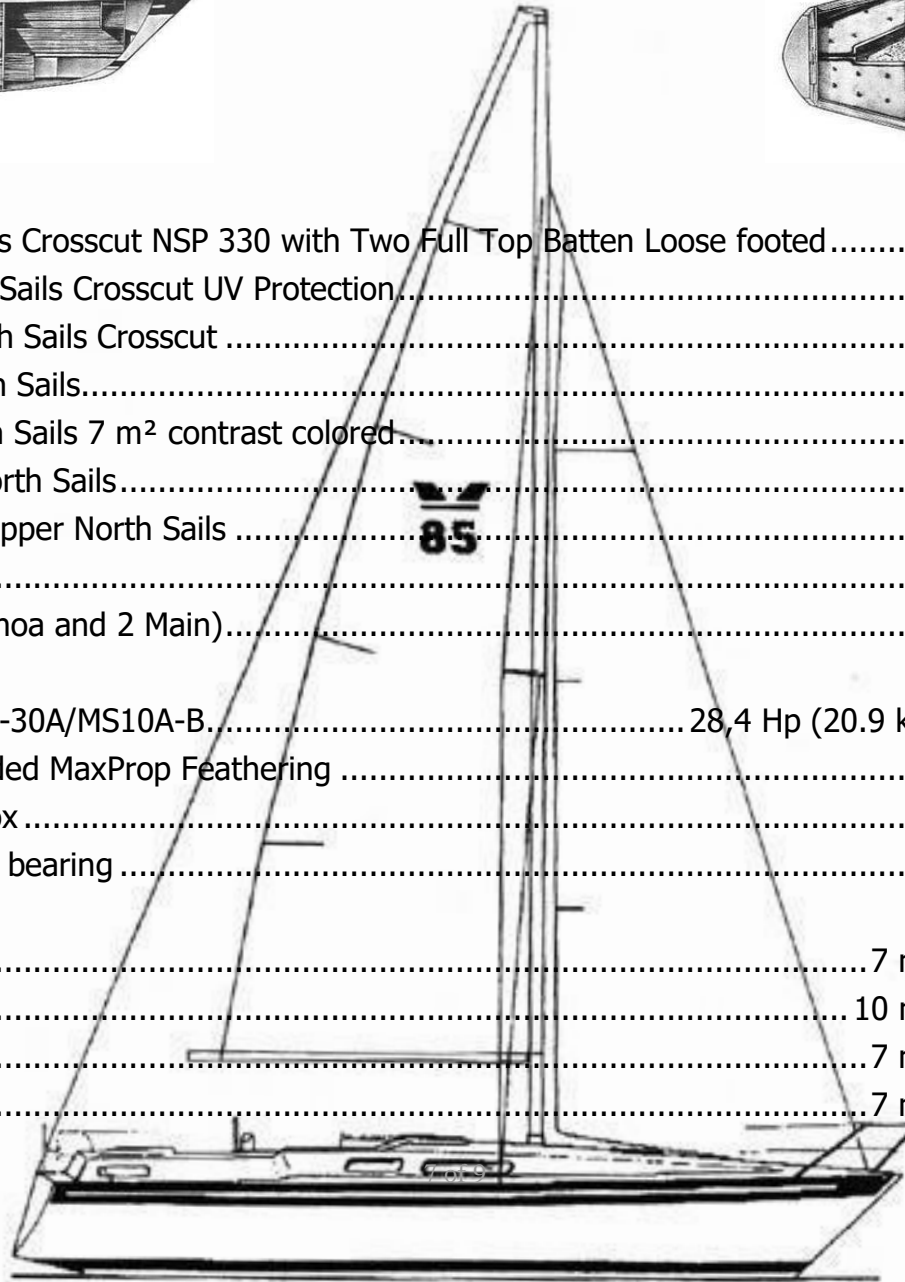
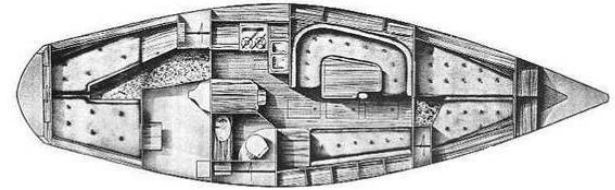
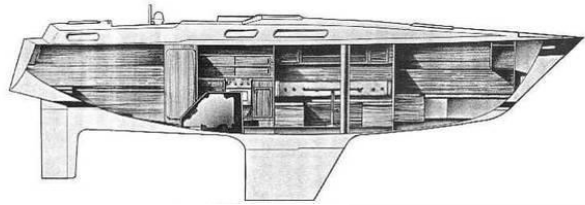

## 5. Sails and Canvases

a. Main North Sails Crosscut NSP 330 with Two Full Top Batten Loose footed.....	2004
b. Genoa 1 North Sails Crosscut UV Protection.....	2000
c. Jib 109 % North Sails Crosscut .....	2006
d. Gennaker North Sails.....	2005
e. Storm Jib North Sails 7 m <sup>2</sup> contrast colored.....	2004
f. Boom Cover North Sails.....	2004
g. Jib Sleeve w/ zipper North Sails .....	2005
h. Bimini top.....	1995
i. Halyards (2 Genoa and 2 Main).....	2004

## 6. Propulsion

a. Volvo Penta D1-30A/MS10A-B.....	28,4 Hp (20.9 kW).....	2006
b. Propeller 2 Bladed MaxProp Feathering .....		2004
c. PSS Stuffing Box .....		2004
d. Caravel Cutlass bearing .....		2004

## 7. Rig

a. Top Shroud .....	7 mm.....	2007
b. Lower Shroud .....	10 mm.....	2004
c. Forward Stay .....	7 mm.....	2007
d. Aft Stay.....	7 mm.....	2007

----- Isabelle -----

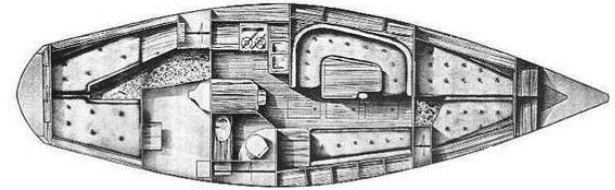
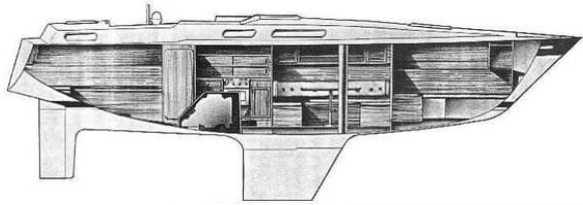

8. Deck, Cabin & Pantry

- a. Hatches (2 ea) Lewmar size 60 medium profile..... 2006
- b. Hatch (1 ea) Lewmar size 30 medium profile..... 2006
- c. Portlights (6 ea) Lewmar size 1..... 2007
- d. Propane Owen..... 1985
- e. Isotherm Compressor Refrigerator..... ?
- f. Potable Water System
  - i. Pressure Controlled Pump Jabsco..... 2007
  - ii. Water faucet at kitchen sink..... 2007
  - iii. Water Heater Isotherm 15L..... 2010

9. Additional Equipment and Inventories

- a. All cushions and mattresses incl. the foam..... 2009
- b. Fujitsu-Siemens S6120 with sea charts..... 2006
- c. Radar Tower Garhauermarine 7'x 2 1/2"..... 2004
- d. Holly Fuel Pump 12 Volt (spare if engine driven would fail)..... 2004
- e. Jabsco Water Puppy 12 Volt (spare if engine driven would fail)..... 2000
- f. 9 ea Fenders..... 2004
- g. 2 ea Anchors (15 kgs plow with 50 ft chain + 10 kgs Bruce)..... ?
- h. 1 ea Marine Binocular Free Focus (built in compass)..... 2000
- i. Computer cable (to get NMEA into Notebook)..... 2007

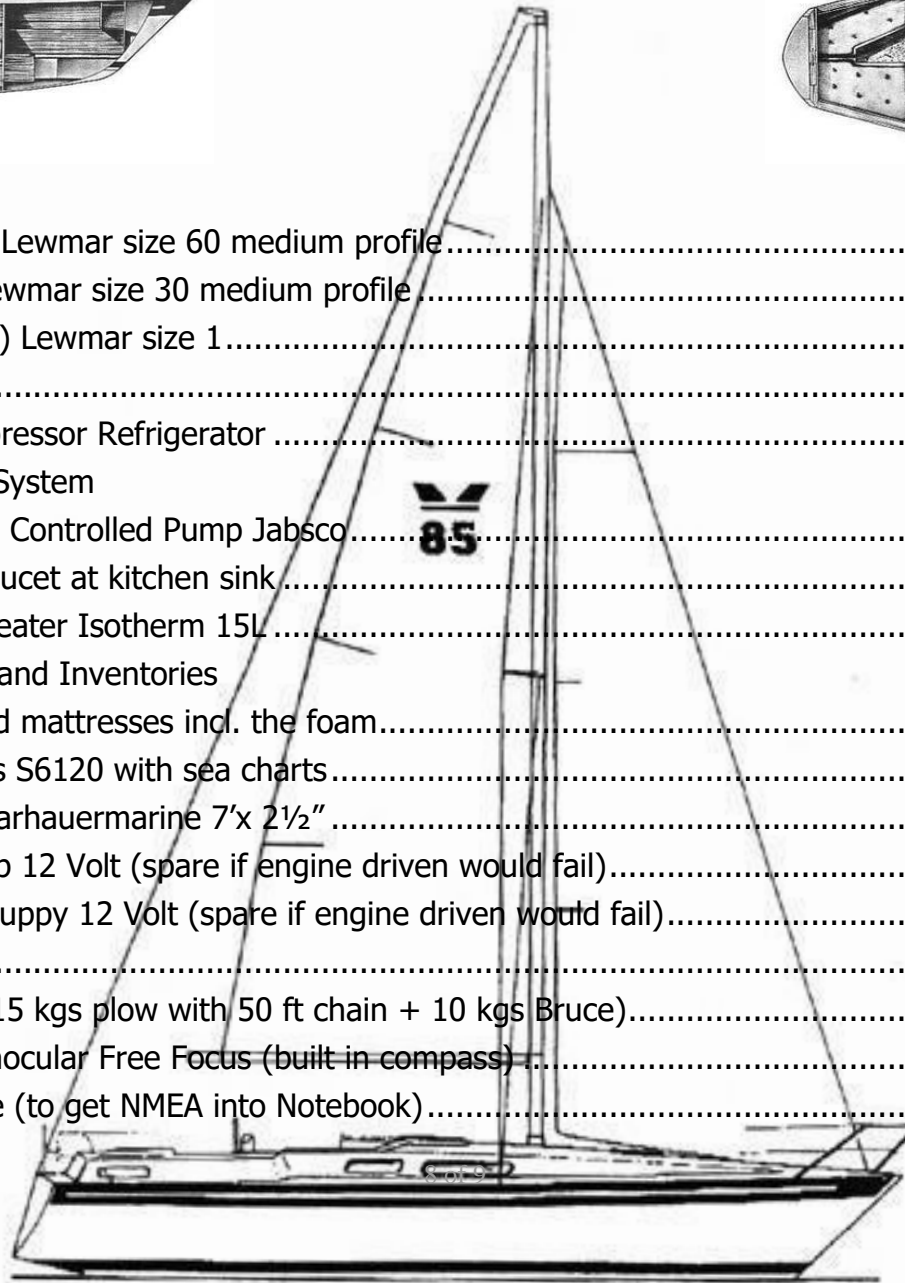



----- Isabelle -----

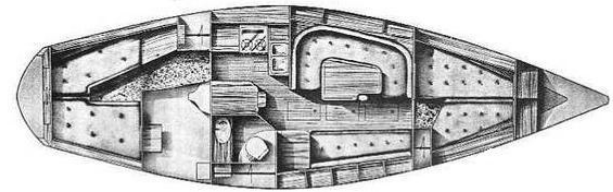
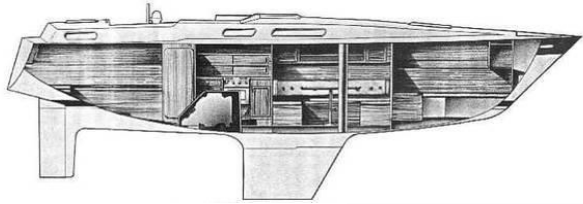

- j. Weems & Plath Electronic Barometer ..... 2004
- k. 1 ea MagLite Flashlight (6 Type D Batteries) ..... 2003
- l. Emergency Steering Tiller, to be inserted thru the roof in aft cabin (made by Scanmar) ..... 1985

