

# max-prop®

Automatic Feathering Propeller

## Installation Instructions

### THREE BLADE CLASSIC

- 1) **INTRODUCTION:** Thank you for having chosen a Max-Prop automatic feathering propeller for your vessel. This instruction booklet is designed to answer all your questions on assembly of the Max-Prop. Please read it carefully and assemble the propeller at least once before installing it on your boat.
- 2) **PITCH ADJUSTMENT** This is a critical step, make sure that you know what pitch to set the propeller at, either by your old propeller or by your engine and reduction ratio.
  - The pitch is adjustable from 10 to 30 degrees of blade angle.
  - Figure 1 shows the conversion from inches of pitch to degrees of blade angle.
  - To properly convert from inches to degrees follow steps A thru C.
  - A) Determine the diameter of your propeller
  - B) Go down the column that corresponds to your propeller diameter until you find the desired amount of pitch.
  - C) Cross reference this pitch in inches to the blade setting angle directly across the chart and you will have the desired blade angle.

		Propeller Diameter in inches														
		12"	13"	14"	15"	16"	17"	18"	19"	20"	21"	22"	23"	24"	25"	26"
Max-Prop Blade Setting Angle	10 deg	4	4.3	4.6	4.9	5.2	5.5	6	6.3	6.7	7.1	7.4	7.7	8	8.3	8.6
	12 deg	4.8	5.2	5.6	6	6.4	6.8	7.2	7.6	8	8.4	8.8	9.2	9.6	10	10.4
	14 deg	5.6	6	6.6	7.1	7.6	8	8.4	8.8	9.4	9.8	10.4	10.8	11.2	11.6	12.2
	16 deg	6.4	6.9	7.6	8.1	8.6	9.1	9.8	10.3	10.8	11.3	12	12.5	13	13.5	14
	18 deg	7.2	7.8	8.6	9.2	9.8	10.4	11	11.5	12.1	12.8	13.4	14	14.6	15.2	16
	20 deg	8.2	8.9	9.6	10.3	11	11.6	12.4	13	13.7	14.5	15	15.6	16.4	17	17.8
	22 deg	9.2	10	10.7	11.4	12.2	12.9	13.6	14.3	15.1	16	16.8	17.5	18.2	18.9	19.8
	24 deg	10	10.9	11.8	12.5	13.4	14.2	15	15.8	16.8	17.6	18.4	19.2	20.2	21	21.8
	26 deg	11	12	12.8	13.8	14.7	15.7	16.6	17.4	18.4	19.3	20.2	21	22	22.9	23.8
	28 deg	12	13	14	15	16	17	18	18.9	20	21	22	23	24	25	26
30 deg	13	14	15.1	16.2	17.3	18.5	19.6	20.6	21.7	22.8	24	25	26.1	27.3	28.2	
		Pitch in inches														

Fig.1

Max-prop offers the great advantage of pitch adjustability in order to optimize the performance of the propeller. If the propeller does not reach the desired RPM, reduce the blade angle. If, on the contrary, the engine exceeds the desired RPM, increase the blade angle. A two degrees change in blade angle will change the engine RPM by 13-15%, at the same boat speed. The adjustment of angle and therefore of pitch is done, when the propeller is mounted on the shaft. To obtain the different values of angle you have to follow the assembly instruction.



12532 Beverly Park Rd  
 Lynnwood, WA 98087  
 Office (425) 355-3669  
 Fax (425) 355-3661  
 Email: [Info@pyiinc.com](mailto:Info@pyiinc.com)  
[www.pyiinc.com](http://www.pyiinc.com)

3) **ASSEMBLY:** Make sure that if you receive more than one propeller that do not interchange parts. Each propeller is individually balanced and if interchanged it will be put out of balance. Please use figure 2 in the instruction book for part number references.

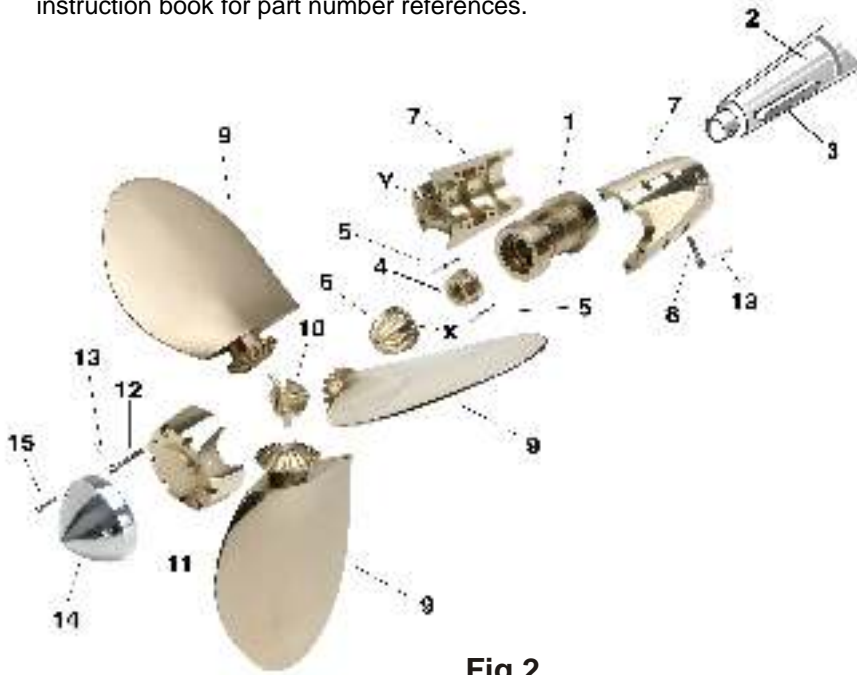
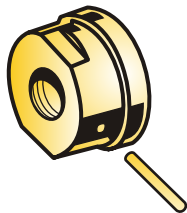

Fig.2

A) Fit the hub (1) to the propeller shaft (2). Be sure that the key (3) is the proper dimension and that the hub slides completely onto the shaft. If you are not sure, remove the key and slide the hub onto the shaft making a mark on the shaft where the hub stops on the shaft. Re-insert the key and slide the hub on to the shaft, if it slides up to your mark, it is fine. If not, you will need to file down the sides or top of the key until the hub slides completely onto the shaft.

B) Two types of nuts are available in the Max-prop:

1) **Drilled Nut:** Tighten the nut (4) onto the shaft and secure it with the pin by drilling a hole completely through the nut and shaft (a cobalt drill bit makes this task easier).



2) **No Drill Nut:** Tighten the nut (4) onto the shaft. Align the groves in the base of the nut with the groves in the central hub, so as to obtain two complete holes allowing insertion of the pins (5). Insert the pins, then rotate the pins are as shown in the drawing below, so as not to interfere with the inserting of the central cone gear (see figure below).

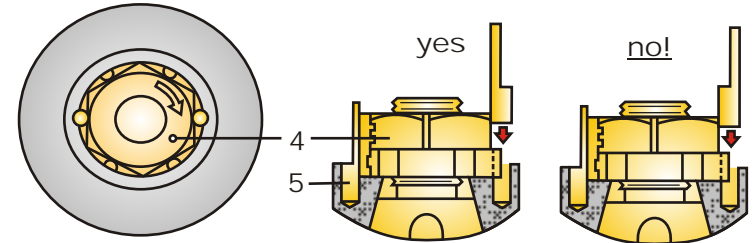

One thread can be exposed aft of either nut system, if more than that are showing it will be necessary to cut off the excess with a hack saw. If too many threads are exposed it will raise the central cone gear (6) and effect the performance of the propeller.

C) On the bottom of the central gear (6) there is a groove on the bottom of one of the teeth, this represents the "X" on the chart in figure 3. Place the tooth with the groove into the corresponding lettered gear on the hub (1).

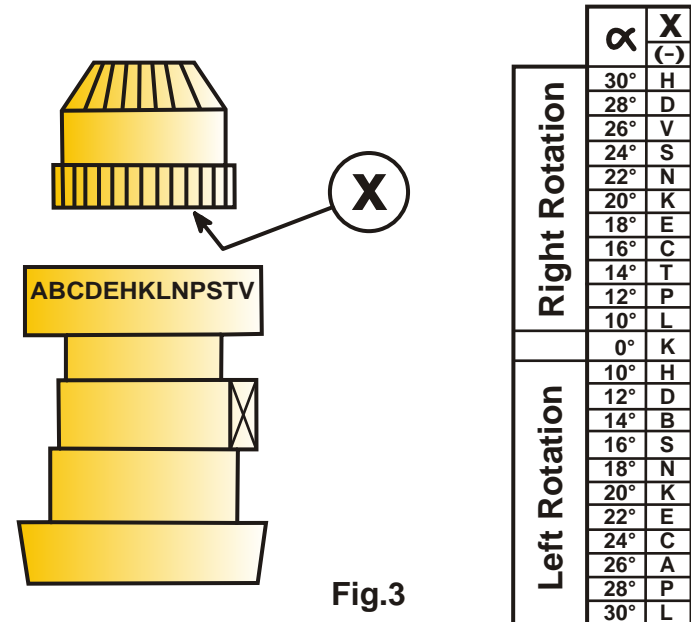

Fig.3

D) Fill the two halves of the spinner (7) with a sea water grease. From our experience Lubraplate "130 AA" grease has worked best. Close the two halves around the hub and tighten down the screws.

**NOTE: DO NOT USE TEFLON GREASE it will wash out very quickly.**

E) Locate the mark on the top inside of the spinner (a small drill hole). This is the "Y" mark in figure 2. Rotate the spinner until the "Y" mark on the spinner coincides with the correct letter on the top of the central cone gear. This letter is determined from the chart in figure 4. Fill the top of the spinner with grease.

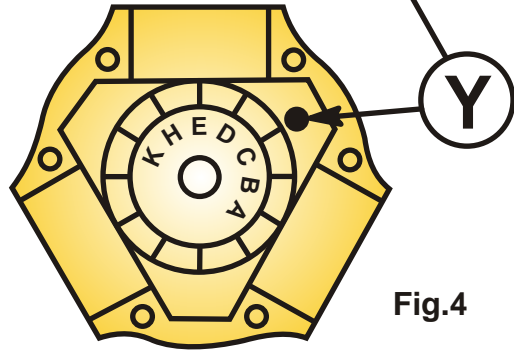
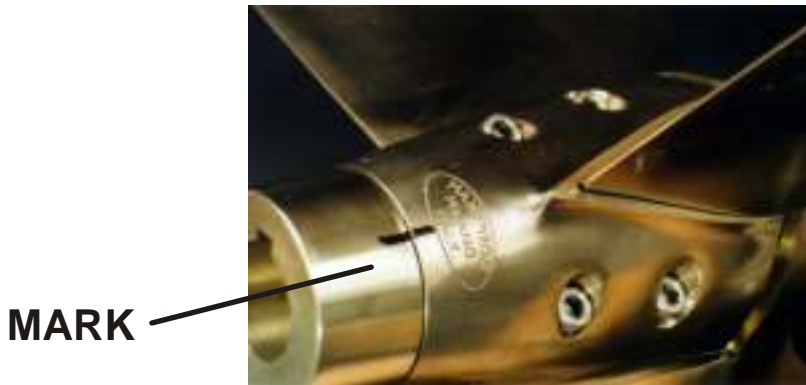

Fig.4

	$\alpha$	Y
		(-)
Right Rotation	30°	H
	28°	K
	26°	B
	24°	C
	22°	D
	20°	E
	18°	H
	16°	K
	14°	B
	12°	C
Left Rotation	10°	D
	0°	D
	10°	D
	12°	E
	14°	H
	16°	A
	18°	B
	20°	C
	22°	D
	24°	E
26°	H	
28°	A	
30°	B	

**NOTE:** It is helpful to make a mark between the spinner and exposed part of the hub or tape them so that any rotation can be noted and corrected. If the spinner is rotated before the blades are attached it will alter the blade angle.



F) Insert the three blades onto the three pins of the spacer (10). Fill the end cap (11) with grease and put the blades into the three seats of the end cap.



**NOTE:** Make sure that the numbers on the blades correspond to the numbers in the spacer and the numbers on the end cap 1 to 1, 2 to 2, and 3 to 3.

G) Move the blades to a feathered position, making sure that the rounded trailing edges of blades are aft as shown in figure 6. Slide the end cap and feathered blades on to the spinner, make sure that the numbers on the blades and spinner match. Next tighten down the end cap with the screws.

**NOTE:** Check to see that the spinner did not rotate. If it did move pull the blades back 1/4" and then realign the mark between the spinner and the hub. Make sure that when the blades go on to the spinner that they are fully feathered.

H) To make the blades rotate more freely it is advisable, after tightening all the screws, to give some bedding blows on the spinner and blades with a plastic or wooden mallet.

I) To make sure that the screws will not loosen insert a 1/16" stainless steel cotter pin into the head of each screw. Put them on so that if the screw were to loosen it would hit the cotter pin as shown in figure 5. Cut the cotter pins to a length of 1/4" and put them in. A tight tap with a hammer on the head of the pin will spread the ends open, if not use a screw driver to spread them apart.

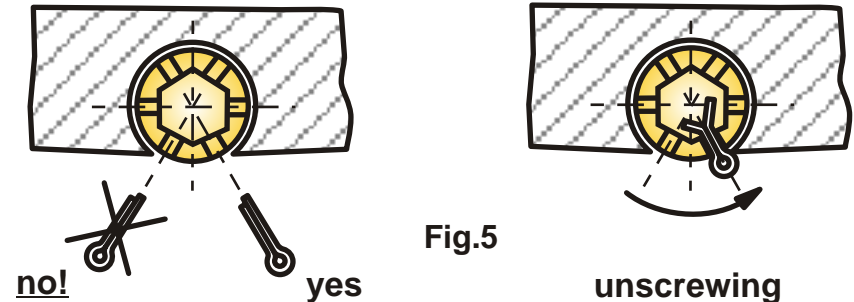

Fig.5

J) Make sure that the propeller is protected from galvanic corrosion by using zinc anodes on the propeller shaft and on the end cap of the propeller. If the propeller has been assembled properly:

- The blades must rotate freely and stop at the blade angle you selected.
- In the feathered position the blades must line up perfectly as in figure 6.
- The propeller must never rotate as shown in figure 7.

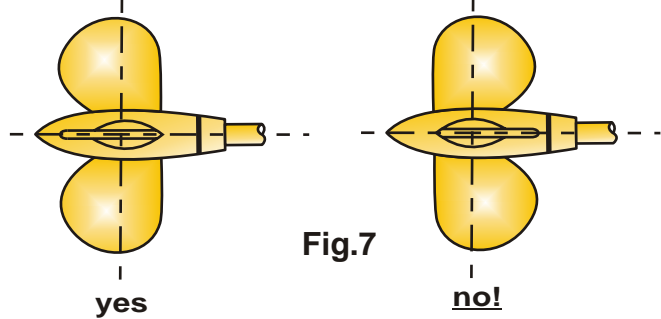

Fig.6

Fig.7

yes

no!

4) **TROUBLE SHOOTING** If the propeller feels stiff or has a hard spot in the rotation systematically go through the points below.

- A) If the propeller does not rotate freely, remove some of the grease from the spinner and reassemble.
- B) Sometimes it can happen that a small piece of metal or burr enters among the gears, or a piece of the propeller has been dinged; in this case the blade movement can become hard. It is necessary then to do as follows, referring to figure 8.

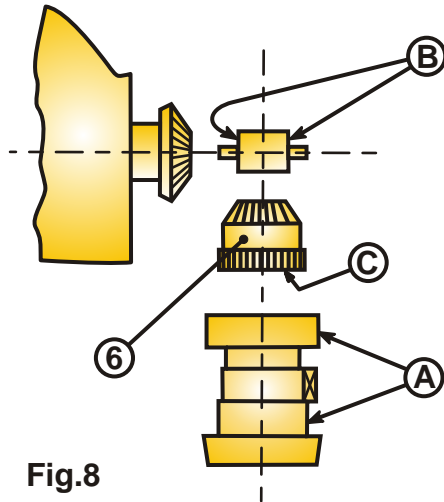

Fig.8

- 1) Open the propeller and assemble it again after having taken the central cone gear (6) out, so that the blade and the hub rotation are independent. If the hub rotation is hard, remove 0.01 mm from surfaces "A" with an emery cloth.

On the contrary if the blades rotation is hard, remove 0.01 mm from surfaces "B" of the spacer using emery cloth wrapped around a flat file. Try until both hub and blades rotate freely.

- 2) Again mount the central cone gear (6) and reassemble the propeller. If the propeller rotation still has some hard points remove 0.1 mm with a flat file from surface (C) so that central cone gear sits lower and the clearance between conical gears increases.

5) **PROPELLER USE** The Max-prop works automatically. By putting the engine in gear the blades will engage in either forward or reverse. The best way to feather the propeller is:

- Power at 2 to 3 knots in forward.
- Kill the engine while still engaged in forward.
- When the engine has stopped, if the shaft is still spinning engage the transmission in reverse to stop the freewheeling.

You can check to see if the propeller is feathered or not by taking the engine out of gear. If the propeller is not feathered the shaft will freewheel like with a fixed blade propeller.

In that case start the engine again and repeat the three steps. If your propeller has been greased properly it will feather in a fraction of a second as soon as you stop the shaft from freewheeling. Once the prop is feathered, you can either leave the transmission in gear or out of gear, it does not matter. **DO NOT** kill the engine while in reverse. In this case the blades will be in the reverse position and will not feather. You can actually use this feature to drive a shaft alternator.

6) **PROPELLER MAINTENANCE** The Max-prop needs to be regreased a minimum of once every two years. We recommend Lubraplate "130 AA" grease.

There are two holes in the spinner of the propeller to grease. Remove the set screw from the forward holes with a #3 metric Allen wrench and screw in the zerc tower, attach your grease gun and fill the propeller with grease until the grease starts to come out between the hub (1) and the spinner (7). Replace the set screw and remove the set screw from the more aft hole. Reinstall the zerc tower and attach your grease gun and fill the propeller with grease until the grease starts to come out between the blades and the spinners. Remove the zerc tower and reinsert the set screw into the propeller. Do not leave the zerc tower in the propeller.



- With each pump of the grease gun rotate the propeller from forward to reverse to allow the grease to work through the propeller.
- The numbers above are from Figure 2 at the beginning of this Max-prop Manual
- **Make sure that you always keep the zinc anodes in good condition.** They must be replaced at least once a year. The propeller must be protected by a lot of zinc, so also use a zinc on the shaft when possible. **When replacing it make sure that you clean the contact point between the zinc and propeller. Use a wire brush or fine sandpaper to clean the aft of the end cap and the forward face of the zinc to give the zinc good contact with the propeller.**

- 7) **PROPELLER REMOVAL** In order to remove the propeller you must first remove the spinner and nut. Be sure only to pull from outside the hub (figure 9). If the surfaces on the hub are hit or dinged it can effect the performance of the propeller.

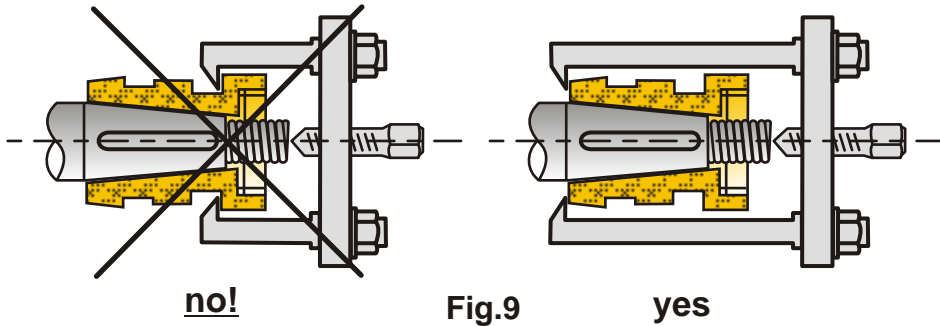

- 8) **WARNING** It is important to follow the instruction below carefully so as to avoid a shock to the gears on the blades and cone gear, that could be damaging to the teeth.
- 1) When going from forward to reverse and the opposite, it is necessary to idle down and shift at low RPM's between gears.
  - 2) The propeller body must always be completely filled with a very fluid grease. This is so when you reverse direction the rotation will be smooth with no binding. Binding points will produce a shock and could damage the gears.

**max-prop®**  
Automatic Feathering Propeller

## Installation Instructions

### THREE BLADE CLASSIC



12532 Beverly Park Rd  
Lynnwood, WA 98087  
Office (425) 355-3669  
Fax (425) 355-3661  
Email: [Info@pyiinc.com](mailto:Info@pyiinc.com)  
[www.pyiinc.com](http://www.pyiinc.com)